

GARANTÍA E INSTRUCCIONES MONTAJE FREGADEROS
GUARANTEE AND ASSEMBLY INSTRUCTIONS
GARANTIE ET INSTRUCTIONS DE MONTAGE
GARANZIA E PRESCRIZIONI DI MONTAGGIO

S E R I E
SUPREME

INSTALACIÓN / INSTALLATION / INSTALLATION / INSTALAZIONE



Bajo encimera

Sistema de instalación que integra el fregadero en la encimera.

Undermount

Installation system that integrates the sink into the countertop.

Sous encastrement

Système d'installation intégrant l'évier au comptoir.

Sotto piano

Sistema di installazione che integra il lavello al piano di lavoro.



Sobre encimera

Sistema de instalación donde el fregadero reposa sobre la encimera.

Inset

Installation system where the sink rests on the countertop.

Sur encastrement

Système d'installation où l'évier repose sur le comptoir.

Sopra piano

Sistema di installazione in cui il lavello appoggia sul piano di lavoro.

Guarantee Number



Para que la garantía tenga validez tiene que preservar ésta hoja

You must preserve this sheet to be effective the warranty

Vous devez garder cette feuille afin d'utiliser la garantie du produit

Affinché la garanzia sia valida, si deve conservare questo foglio



Apdo. de correos 72

C/ Malvasia parc. 9 y 11 - Polígono Industrial Pino Blay - 46380 Cheste - Valencia - Spain

Tels.: +34 962 512 894 / +34 960 702 381

e-mail: admon@mundilite.com

www.mundilite.com

SERIE SUPREME

Medidas del hueco / Fits cabinet
 Mesures de la cavité / Misure del vano

Sobre encimera
 hole on top
 sur encastrement
 filo top



Bajo encimera
 as low top
 sous encastrement
 sottotop



Supreme 780

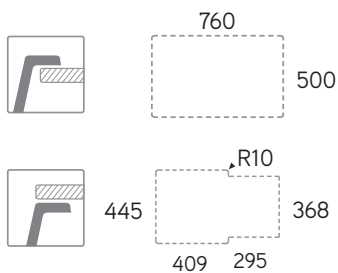
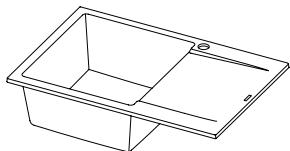

Supreme 880

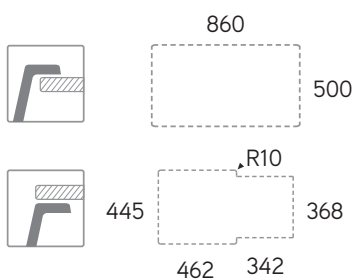
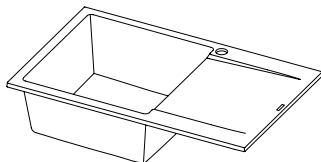

Supreme 980

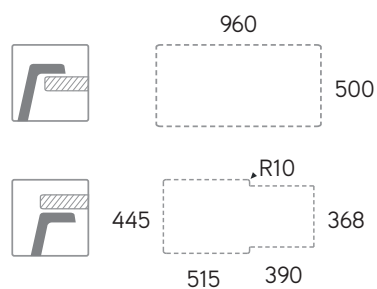
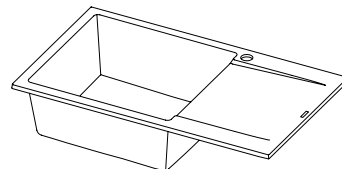

Supreme 760

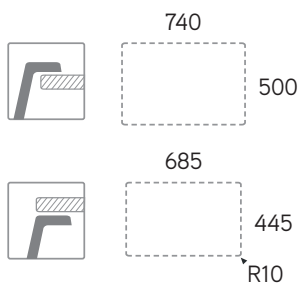
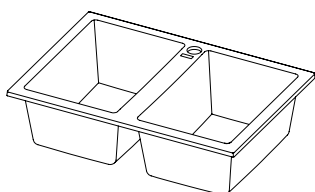

Supreme 860

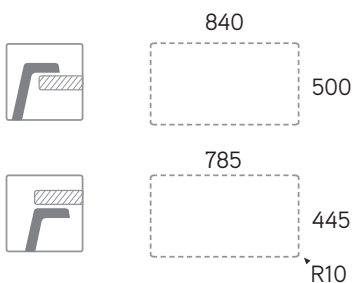
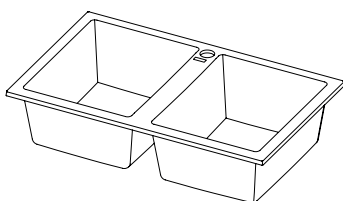

Supreme 960

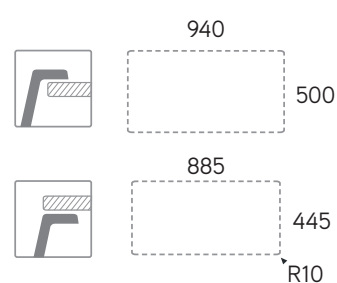
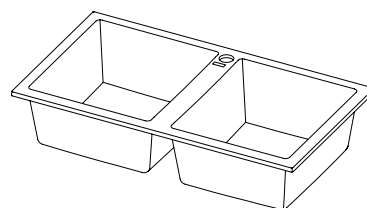

Supreme 1180

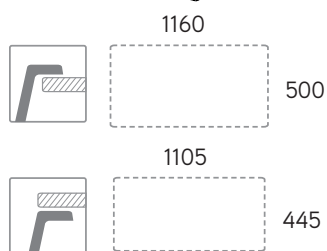
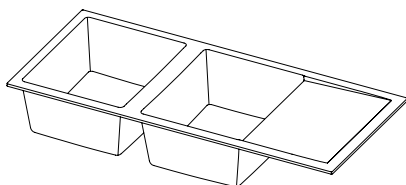

Supreme E830

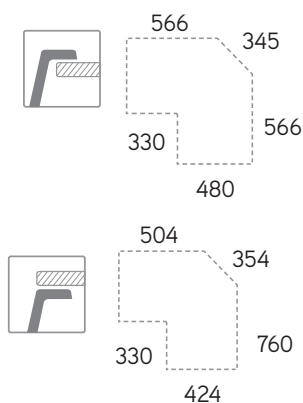
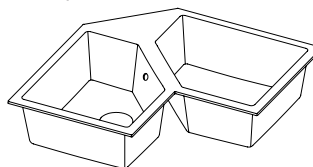

Herramientas / Tools / Outils / Strumenti di costruzione

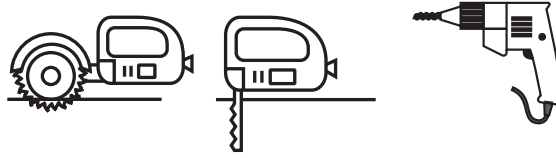

Nuestros fregaderos pueden tener una tolerancia de +/- 1% respecto a las dimensiones especificadas, debido a las propiedades del material utilizado en el proceso de fabricación.

Our products can have a tolerance of +/- 1% with respect to the specified dimensions, due to the properties of the material used in the manufacturing process.

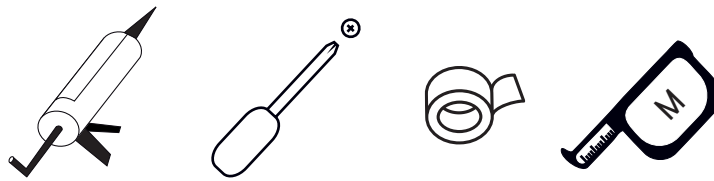

Nos produits présentent une tolérance de +/- 1% par rapport aux dimensions précisées, en raison des propriétés du matériau utilisé dans le processus de fabrication.

I nostri prodotti possono avere una tolleranza di +/- 1% rispetto alle dimensioni specificate, a causa delle proprietà del materiale utilizzato in fase di produzione.

SOBRE ENCIMERA / HOLE ON TOP / SUR ENCASTREMENT / FILO TOP

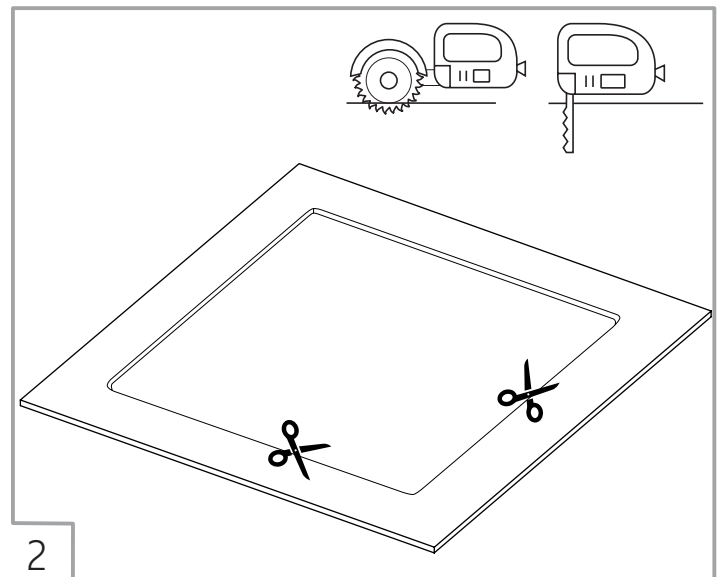
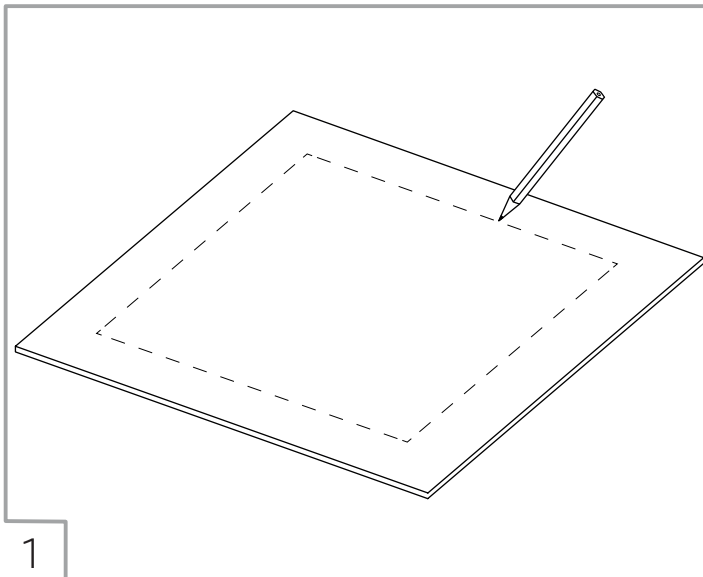

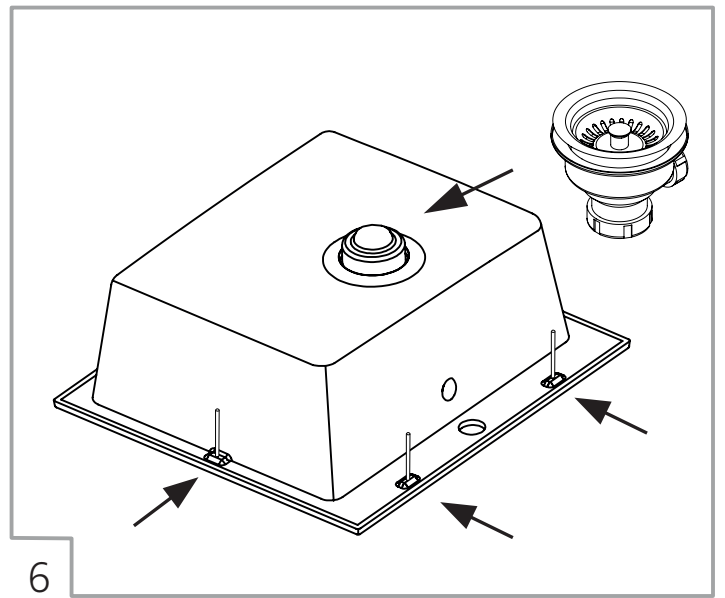
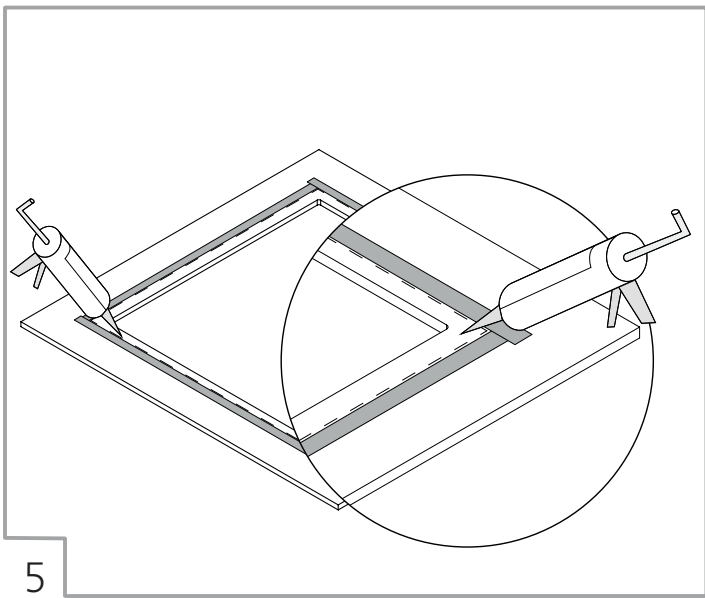
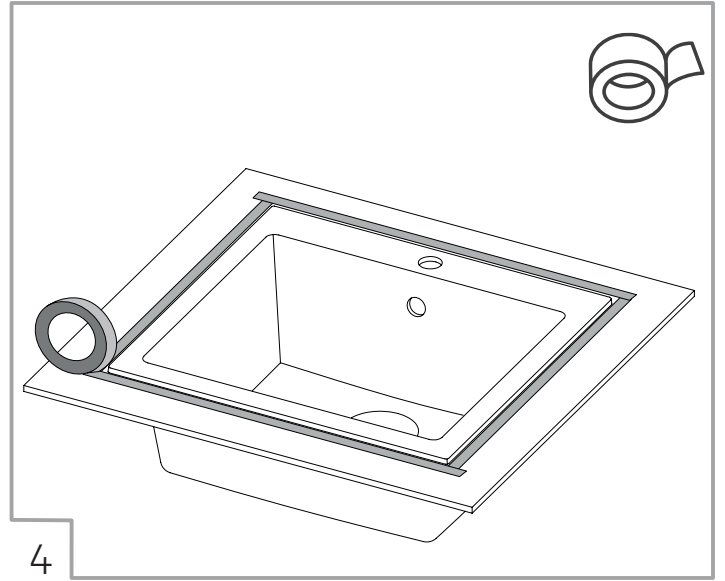
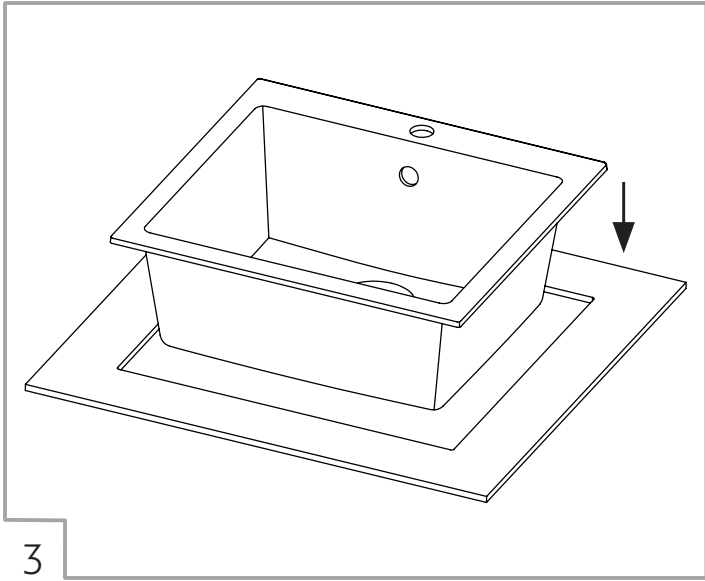

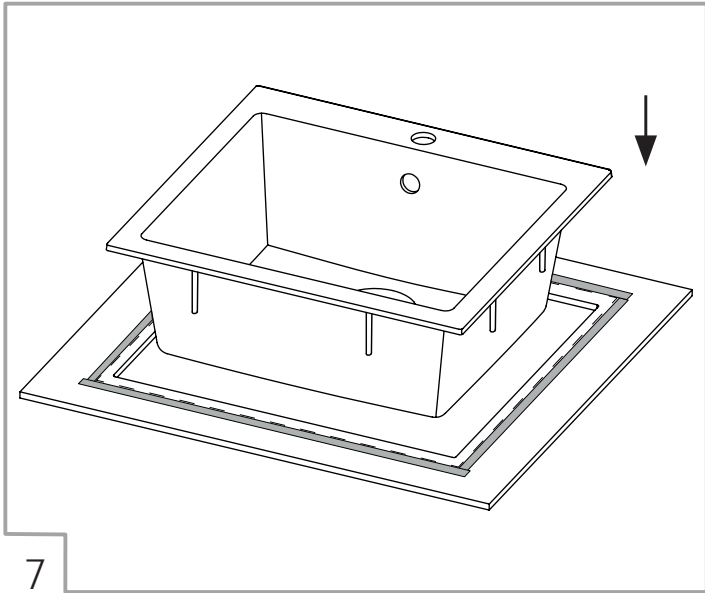

7

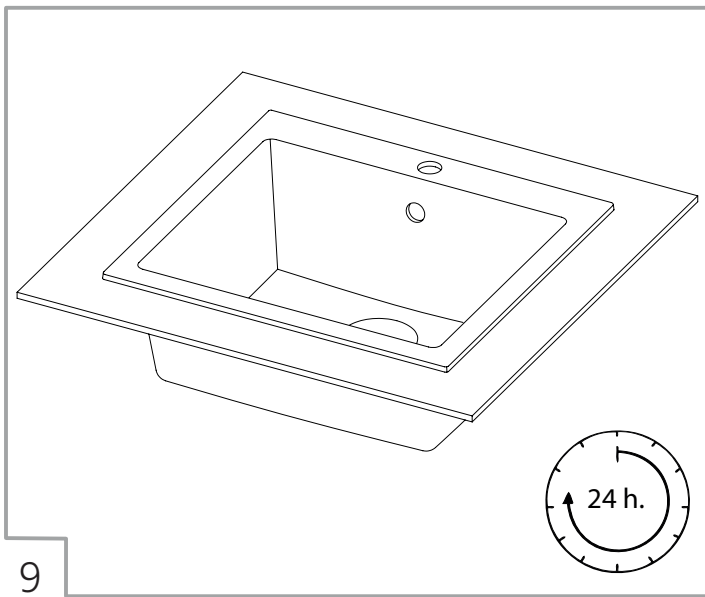

9

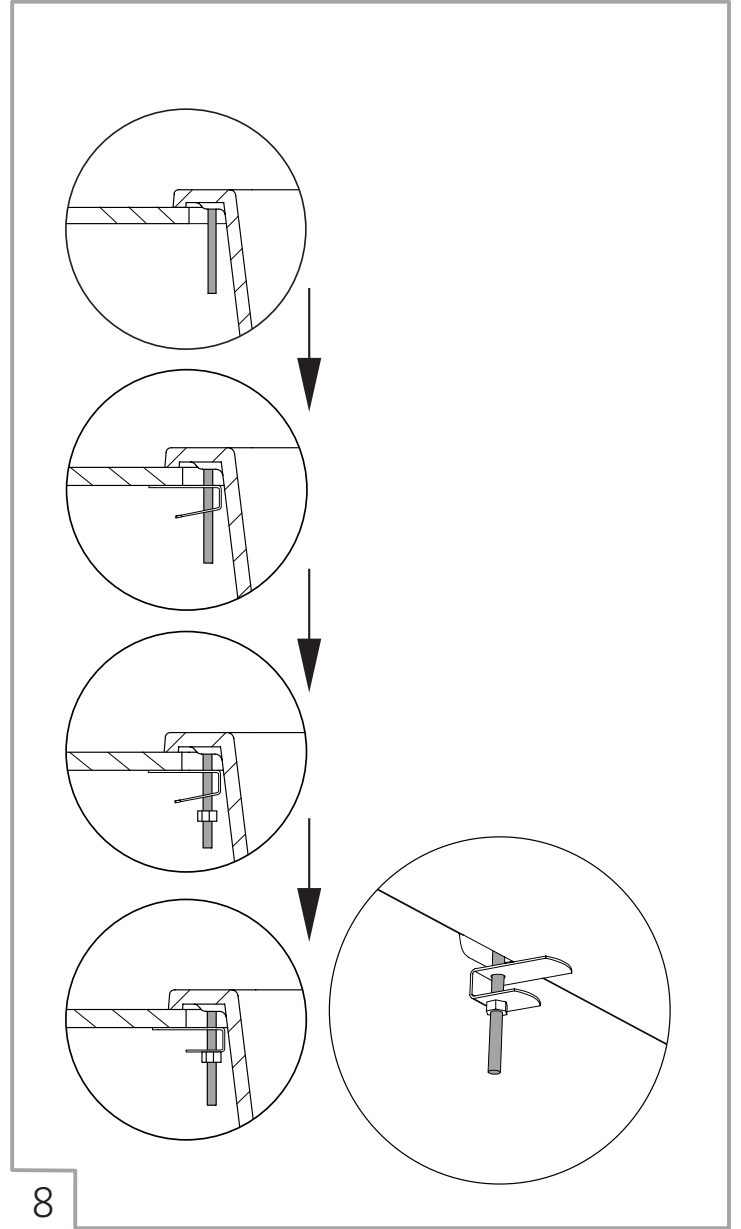

8

BAJO ENCIMERA / AS LOW TOP / SOUS ENCASTREMENT / SOTTOTOP

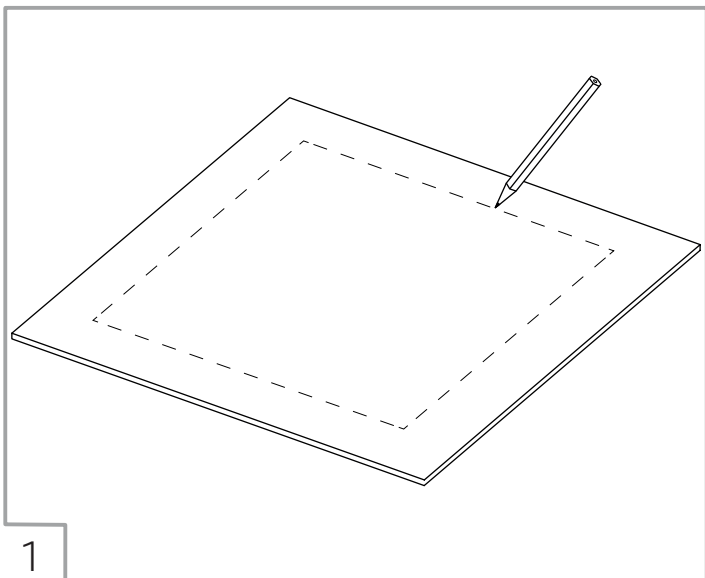

1

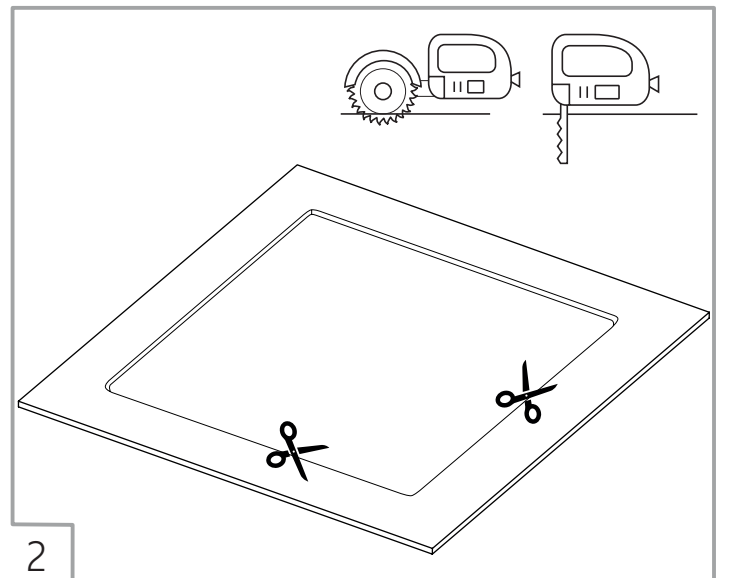

2

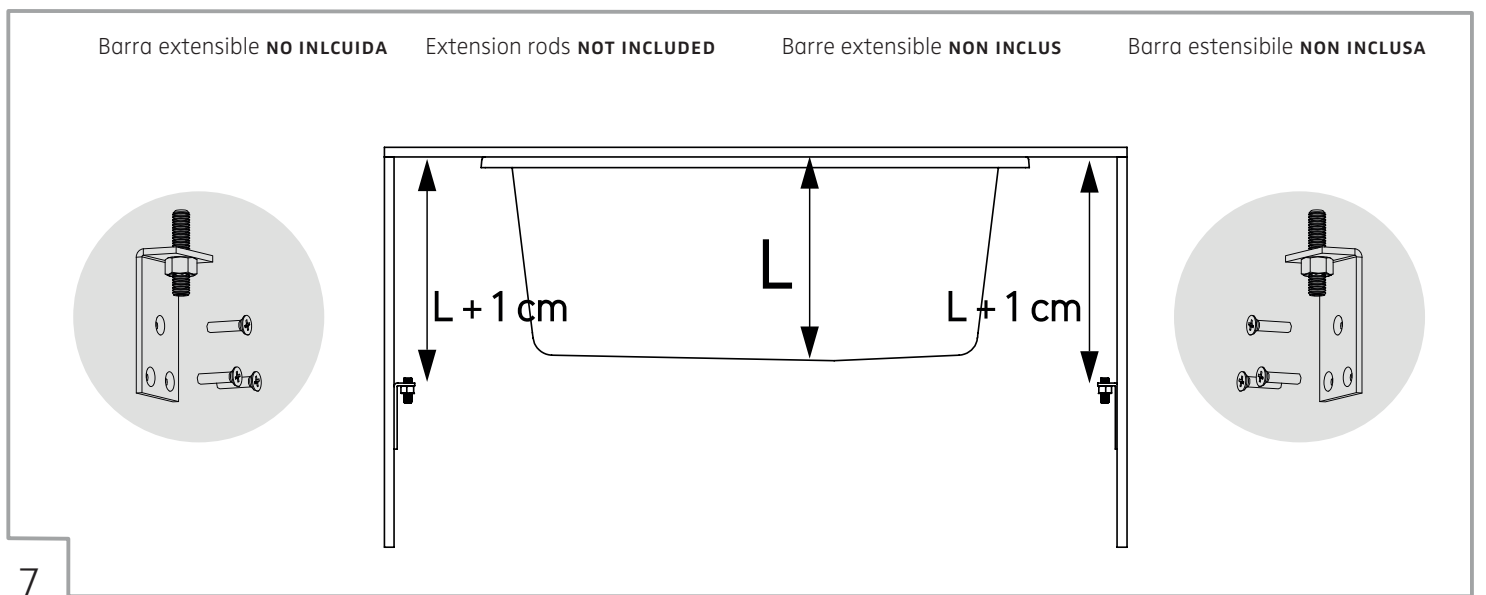
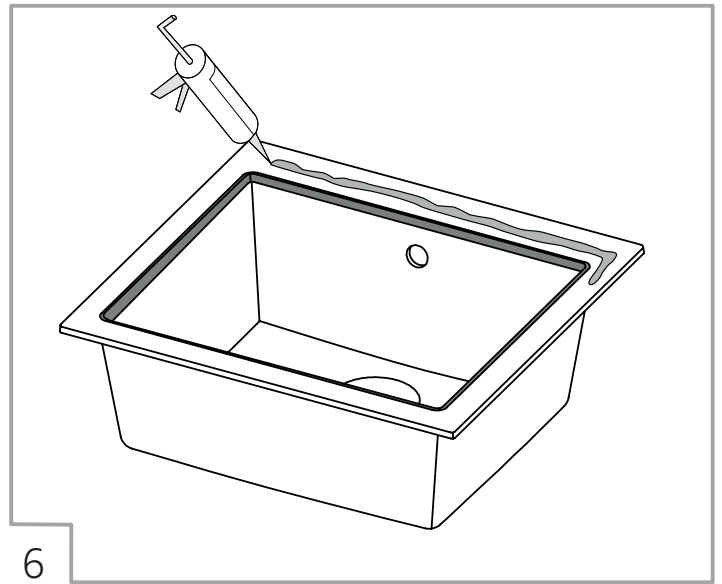
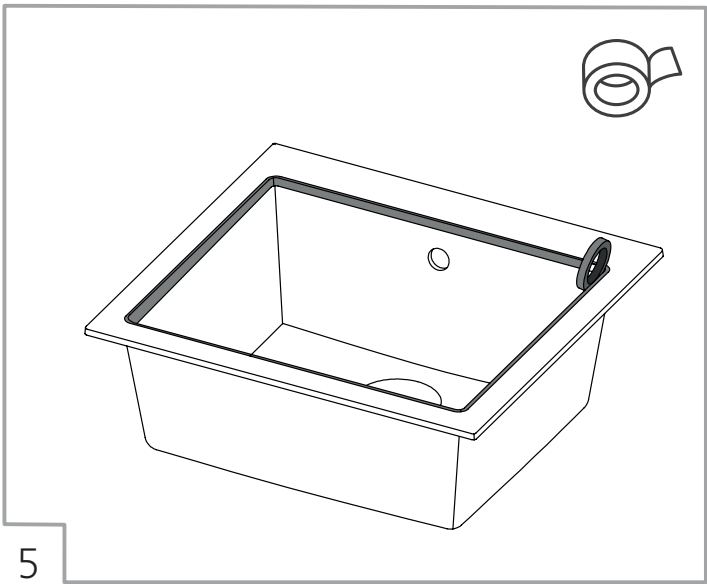
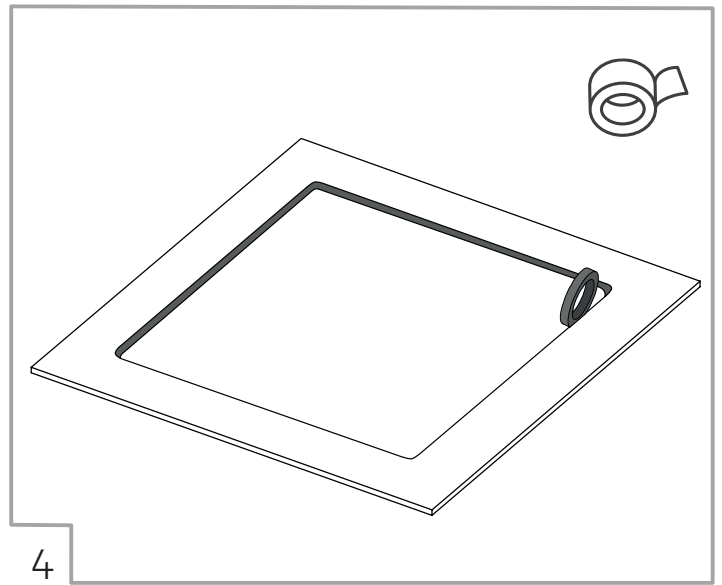
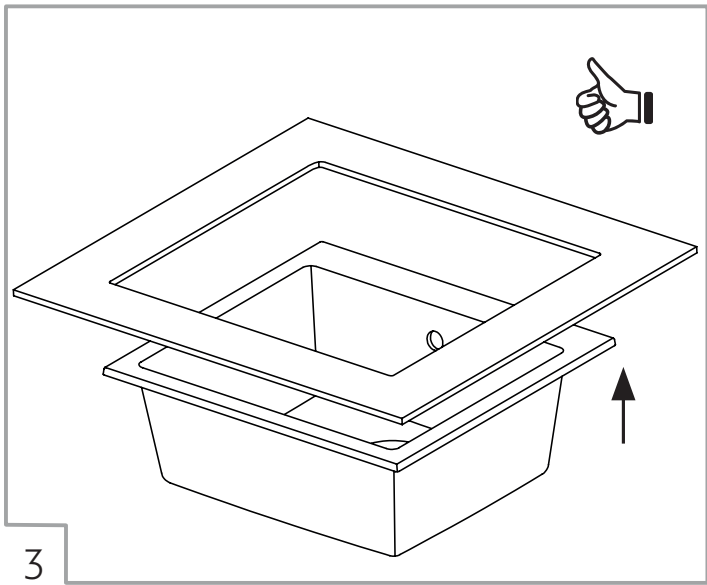

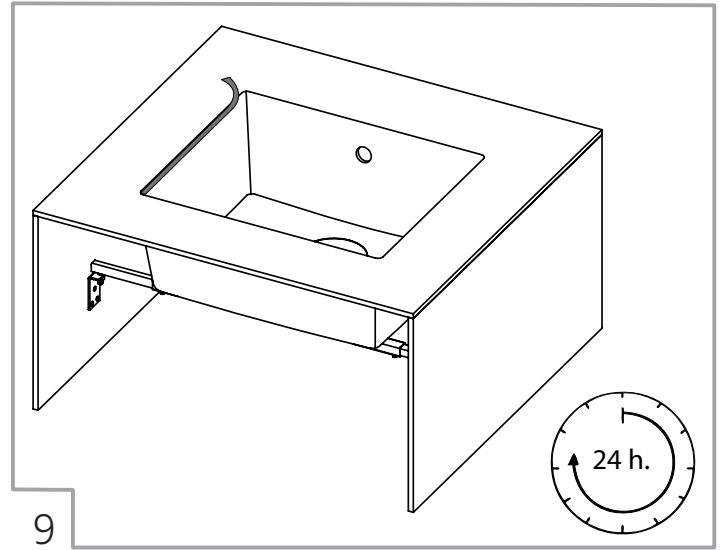
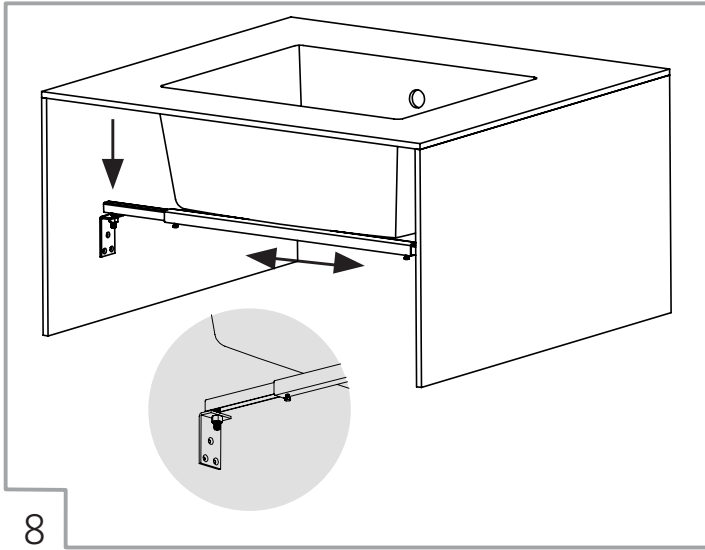

Barra extensible / Extension rods / Barre extensible / Barra estensibile

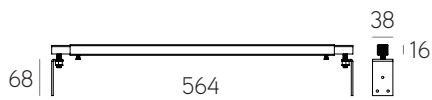

Extensión mínima / Minimum dimensions
Extension minimale / Estensione minima



Extensión máxima / Maximum dimensions
Extension maximale / Estensione massima

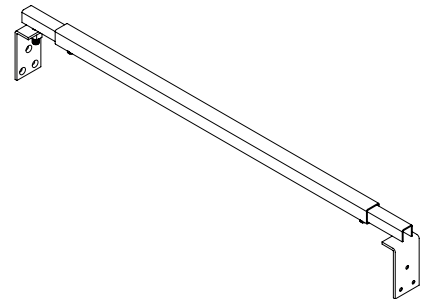

5 Garantía

Todos nuestros fregaderos tienen una garantía por el plazo de cinco años a partir de su fecha de compra. Los fregaderos de éste catálogo han sido diseñados para un uso doméstico y deben ser instalados por personal cualificado, un mal uso, una instalación incorrecta o, una reparación no autorizada por el fabricante, anulan automáticamente la garantía. En el caso improbable de sufrir una avería o defecto en el producto, Mundilite ofrecerá la posibilidad del cambio o reparación del producto (en ningún caso el reembolso económico) dependiendo de la magnitud de la avería, y siempre a través del comercio donde se adquirió el producto. Para que la garantía sea efectiva, habrá un reconocimiento explícito por parte de nuestro departamento de calidad, de que el defecto o merma está contemplado en los supuestos que cubre la garantía. La garantía no contempla gastos de montaje o desmontaje, instalación, o indemnización alguna por daños ocasionados directa o indirectamente.

5 Garantie

Tous nos éviers ont une garantie de cinq ans à compter de la date d'achat. Les éviers de ce catalogue ont été conçus pour un usage domestique et doivent être installés par du personnel qualifié ; une mauvaise utilisation, une installation incorrecte ou une réparation non autorisée par le fabricant annulent automatiquement la garantie. Dans l'éventualité peu probable d'une défaillance ou d'un défaut du produit, Mundilite offrira la possibilité de changer ou de réparer le produit (en aucun cas le remboursement économique) en fonction de l'étendue de la défaillance, et toujours par le biais du magasin où le produit a été acheté. Pour que la garantie soit effective, notre service de la qualité doit reconnaître explicitement que le défaut ou la défaillance relève des cas couverts par la garantie. La garantie n'inclut pas les frais de montage ou de démontage, d'installation ou de réparation des dommages causés directement ou indirectement.

5 Warranty

All our sinks have a five-year warranty from the purchase date. The sinks in this catalog have been designed for domestic use and must be installed by qualified personnel; misuse, incorrect installation or, a repair not authorized by the manufacturer, automatically void the warranty. In the unlikely event of a fault or defect in the product, Mundilite will offer the chance to change or repair the product (not a refund in any circumstances) depending on the magnitude of the damage, and always through the store where the product was purchased. For the warranty to be effective, there will be an explicit acknowledgment by our quality department that the defect or wastage is set out in the circumstances covered by the warranty. The warranty does not include assembly or disassembly costs, installation, or compensation for damages caused directly or indirectly.

5 Garanzia

Tutti i nostri lavelli hanno una garanzia di cinque anni a partire dalla data di acquisto. I lavelli in questo catalogo sono stati progettati per un uso domestico e devono essere installati da personale qualificato. Un uso improprio, un'installazione errata o una riparazione non autorizzata dal produttore annullano automaticamente la garanzia. Nell'improbabile eventualità di un guasto o di un difetto nel prodotto, Mundilite offrirà la possibilità di cambiare o riparare il prodotto (in nessun caso un rimborso economico) a seconda dell'entità del danno, e sempre tramite il punto vendita in cui è stato acquistato il prodotto. Affinché la garanzia sia efficace, sarà necessario un riconoscimento esplicito da parte del nostro reparto qualità del fatto che il difetto o guasto è previsto nei casi coperti dalla garanzia. La garanzia non include le spese di montaggio o di smontaggio, l'installazione o il risarcimento dei danni causati direttamente o indirettamente.